

MOTOR OPERATOR—MODEL MO**

08330/ATL
Buyline 0371

SPECIFICATIONS

PART 1 GENERAL

1.01 Section Includes

A. Type: The motor operator will be Atlas Door™ Model MO as manufactured by Clopay Building Products Company, Inc.

B. Mounting: To be vertical front of hood.

1.02 Related Work

A. Electrical wires, wiring, disconnect switches, and conduit are in the scope of work of other sections or trades.

B. Submit manufacturer's product data and installation instructions for each type of coiling door. Include both published data and any specific data prepared for this project.

1.03 Single-Source Responsibility

A. Provide doors, guides, motors, and accessories from one manufacturer for each type of door. Provide secondary components from source acceptable to manufacturer of primary components.

PART 2 PRODUCT

2.01 Operator

A. Motor: Provide high torque, continuous duty motor of horsepower determined by size and weight of coiling product (see chart). Motor shall be separate from reduction mechanism for ease of maintenance. (Specify voltage & phase available.)

B. Reduction: To be heavy-duty worm gear running in oil with additional reduction by chain and sprockets.

C. Drive: Product shaft to be driven by roller chain to provide curtain travel of 6" (152.4 mm) to 12" (304.8 mm) per second.

D. Brake: To be solenoid activated wheel type.

E. Electrical Enclosure: All electrical components shall be in a NEMA 1 enclosure and pre-wired to terminal block.

F. Reversing Contactor: Heavy-duty across the line reversing type with mechanical interlock. Size "00."

G. Limit Switches: To be positive chain drive screw type limit switch, enclosed in electrical control box, easily accessible for precision setting. Limit switches will remain in time when emergency chain hoist is used to operate manually.

H. Control Circuit: Shall be reduced to 24 volts for safety.

I. Overload Protection: To be thermal type with automatic reset.

J. Emergency Operation: To be by a floor operated chain hoist which must be engaged for manual mechanical operation. An electrical interlock disconnects power to the motor operator when chain hoist is engaged.

K. Control Station: To be one NEMA 1 three-button-station with open, close and stop functions. Momentary contact to open and stop, constant pressure to close.

L. Assembly: To be C.S.A. and UL listed.

PART 3 EXECUTION

3.01 Examination

A. Verify that dimensions are correct and project conditions are suitable for installation. Do not proceed with installation until unsatisfactory conditions have been corrected.

3.02 Installation

A. Installation: To be by an authorized Atlas Door representative and in accordance with Atlas Door standards and instructions.

B. Submit manufacturer's product data and installation instructions for each type of coiling door. Include both published data and any specific data prepared for this project.

Note To Specifiers... Please see end of this section for frequently specified Optional Features.

AMPERAGE & HORSEPOWER

HP	Motor	Service Doors Steel Gauge			Insulated Doors Std. Gauge	Fire Doors Steel Gauge			Rolling Grilles Aluminum	Shutter	HP	Voltage	Phase	AMP
1/8 HP	MO-50	20	20	18	210	N/A	N/A	N/A	500	520	1/8 HP	115	1	3.2
1/8 HP	MO-75	N/A	338	330	230	N/A	N/A	N/A	N/A	N/A	208	1	4.1	
1 HP	MO-100	N/A	N/A	450	350	N/A	N/A	N/A	N/A	N/A	208-230	3	2.1	
1 1/2 HP	MO-150	N/A	N/A	475	400	N/A	N/A	N/A	N/A	N/A	460	3	1.05	
2 HP	MO-200	N/A	N/A	595	490	N/A	N/A	N/A	N/A	N/A	575	3	0.77	
					660	N/A	N/A	N/A	N/A	N/A	1/4 HP	115	1	13.0
											208	1	6.5	
											208-230	3	3.6	
											460	3	1.8	
											575	3	1.03	
											1 HP	115	1	15.4
											208	1	7.7	
											208-230	3	6.0	
											460	3	3.0	
											575	3	1.4	
											1 1/2 HP	115	1	20.0
											208	1	10.0	
											208-230	3	6.8	
											460	3	3.4	
											575	3	1.8	
											2 HP	230	3	6.8
											460	3	3.4	
											575	3	2.4	

MOTOR OPERATOR-MODEL MO**

08330/ATL
Buyline 0371

- 1/2 H.P. to 2 H.P.
- Emergency Hand Chain

Used on:
Service Doors - "S" Series
Insulated Doors - "T" Series
Coiling Grilles - "G" Series
Side Coiling Doors/Grilles - "H" & "K" Series
**Suffix indicates Horsepower required - see chart on back

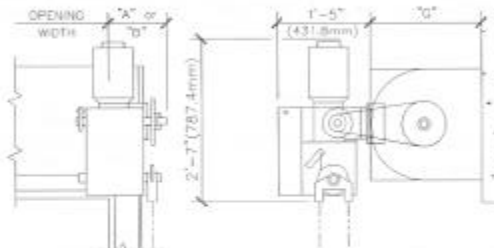
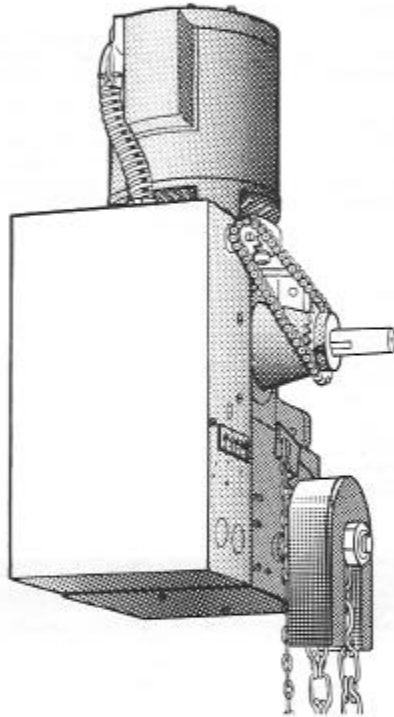

VERTICAL FRONT OF HOOD

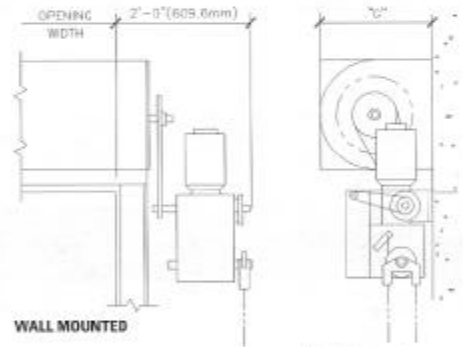

WALL MOUNTED

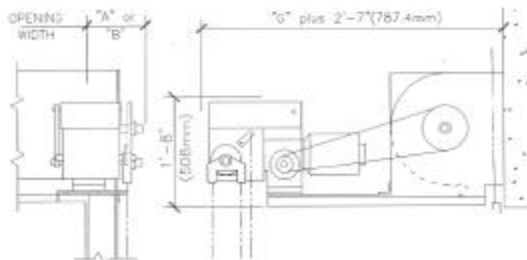

HORIZONTAL FRONT OF HOOD

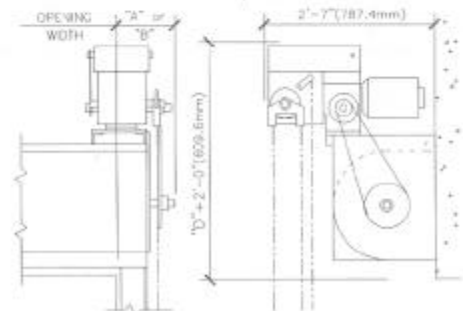

HORIZONTAL TOP OF HOOD

atlas door